

NOTICE:

Prices and availability are subject to change without notice.

Please contact Marlin Manufacturing before ordering for updated pricing.

CONNECTORS MINI CRIMPING TOOL, MISC. ACCESSORIES

Adapter Crimping Tools provide fast and easy installation of Plugs and Jacks to metal sheathed thermocouple wire. The hand held tool crimps the brass adapter for miniature connectors onto the metal sheath and eliminates the need to braze or solder. The tool is engineered to insure a positive crimp. Jaws cannot be reopened until the full crimp stroke has been made.

To install, strip sheath from cable to expose wires. Place crimp-on sheath adapter over sheath, hex end toward stripped wires. Position tool jaws over adapter and crimp.

DISCOUNT SCHEDULE "A"	
QUANTITY	FACTOR
1-14	NET
15-49	.90
50-99	.85
100-249	.80
250-499	.75
500-999	.70
1000-1999	.65
2000+	.60

DESCRIPTION	CODE NO.	*PRICE
Hand-Crimping Tool	1251	\$110.00

*No Discounts

MINI HEX CRIMP-ON ADAPTERS

SHEATH OD	CODE NO.	PRICE	DISC. SCHED.
Blank	1275-Blank	\$0.40	A
.020"	1275-020	1.20	
.040"	1275-040	0.40	
1/16	1275-062	0.40	

DESCRIPTION	CODE NO.	PRICE	DISC. SCHED.
Elastomer Grommet Wire grip	1279	\$0.15	A

MINI WATER SEAL BOOTS

DESCRIPTION	CODE NO.	PRICE	DISC. SCHED.
Miniature Water Seal Boot	1291	\$1.10	A

Two Required for Connector Pair.
For use to 212°F (100°C), stiffens at -37°F (-35°C).

FULL SIZE WATER SEAL BOOTS

DESCRIPTION	CODE NO.	PRICE	DISC. SCHED.
Standard Water Seal Boot	1091	\$1.40	A

Two Required for Connector Pair.
Neoprene for use to 212°F (100°C), stiffens at -37°F (-35°C)

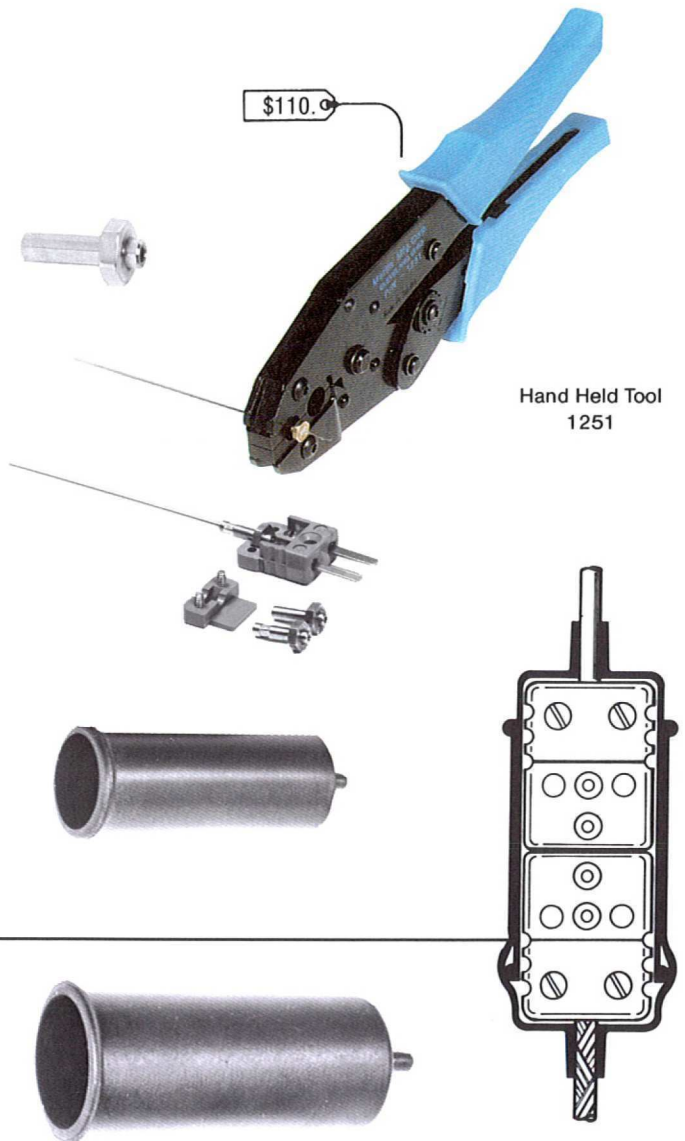

CONNECTORS MINI PLUGS AND JACKS

MINI PLUGS AND JACKS			400°F Continuous Ambient			800°F Continuous Ambient			
THERMOCOUPLE TYPE	TYPE CODE	COLOR	PLUG CODE NO.	JACK CODE NO.	DISCOUNT SCHEDULE	COLOR	HI TEMP PLUG CODE NO.	HI TEMP JACK CODE NO.	DISCOUNT SCHEDULE
Iron Constantan	J	Black	1260-() TYPE Code → \$2.65	1210-() TYPE Code → \$3.30	A	Red	1360-() TYPE Code → \$4.25	1310-() TYPE Code → \$5.25	B
Copper Constantan	T	Blue				Red			
Chromel™ Alumel™	K	Yellow				Red			
Nicrosil Nisil	N	Orange				Red			
Chromel™ Constantan	E	Violet				Red			
Platinum 10% Rhodium	S	Green				Red			
Platinum 13% Rhodium	R	Green				Red			
Uncompensated (CU)	U	White				Red			
Tungsten 5% Re/W26% Re	C	Brown	\$3.65	\$4.30	B	Red	\$5.25	\$6.25	B

1.) Gold plated contacts are available at \$1.00 added to list price. Use suffix "G" (i.e. 1260-K-G)

Grommet Wire Grip			
Code No.	Size	\$/Each	Discount Schedule
1279-030	.030"	0.15	A
1279-062	.062"	0.15	
1279-090	.090"	0.15	

Option 1: Grommet is furnished with each connector at no cost. Give part number of desired size otherwise 1279-062 is furnished as the standard package.

Mini Braze-on Adapter			
Code No.	Size	\$/Each	Discount Schedule
1277-000	blank	0.30	A
1277-040	.040"	0.30	
1277-062	.062"	0.30	
1277-090	.090"	0.30	
1277-125	.125"	0.30	

Option 2: Braze-on Adapter is furnished with each connector at no cost instead of grommets specified. Give part number of desired size.

Mini Hex Crimp Adapter			
Code No.	Size	\$/Each	Discount Schedule
1275-000	blank	0.40	A
1275-020	.020"	1.30	
1275-040	.040"	0.40	
1275-062	.062"	0.40	

Mini 2-Pole Crimp Adapter			
Code No.	Size	\$/Each	Discount Schedule
1274-040	.040"	1.75	B
1274-062	.062"	1.75	
1274-125	.125"	1.75	

Mini Wire Clamp		
Code No.	\$/Each	Discount Schedule
1280	1.25	B

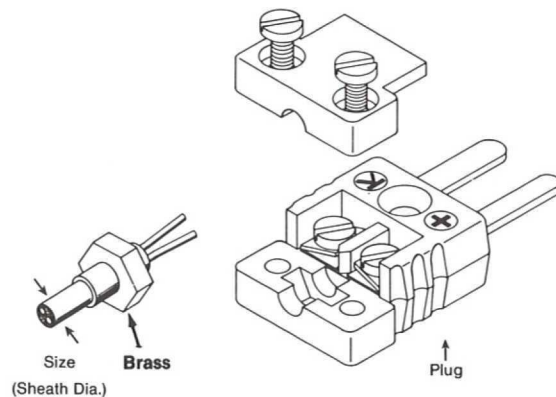
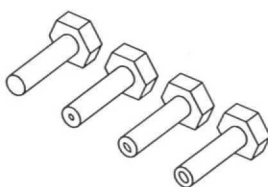
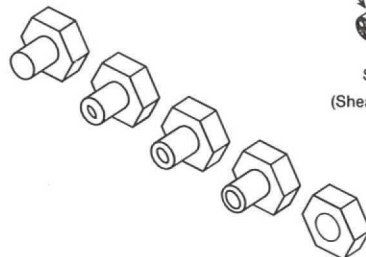

DISCOUNT SCHEDULE "A"	
QUANTITY	FACTOR
1-14	NET
15-49	.90
50-99	.85
100-249	.80
250-499	.75
500-999	.70
1000-1999	.65
2000+	.60

DISCOUNT SCHEDULE "B"	
QUANTITY	FACTOR
1-14	NET
15-49	.90
50-99	.85
100-249	.80
250+	.75

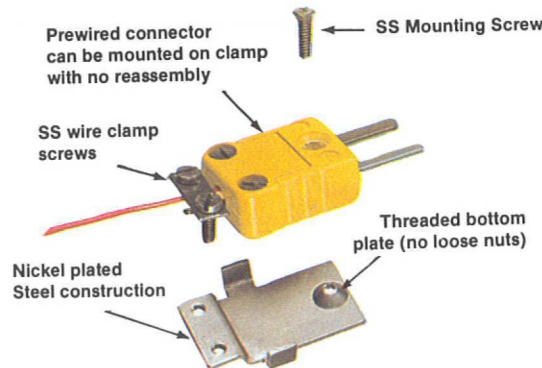

MINI WIRE CLAMP
Strain relieves fine wire as well as heavy insulated wire.

